

REVISIONS		
REV.	DESCRIPTION	DATE
01	INITIAL RELEASE	2014 03 12

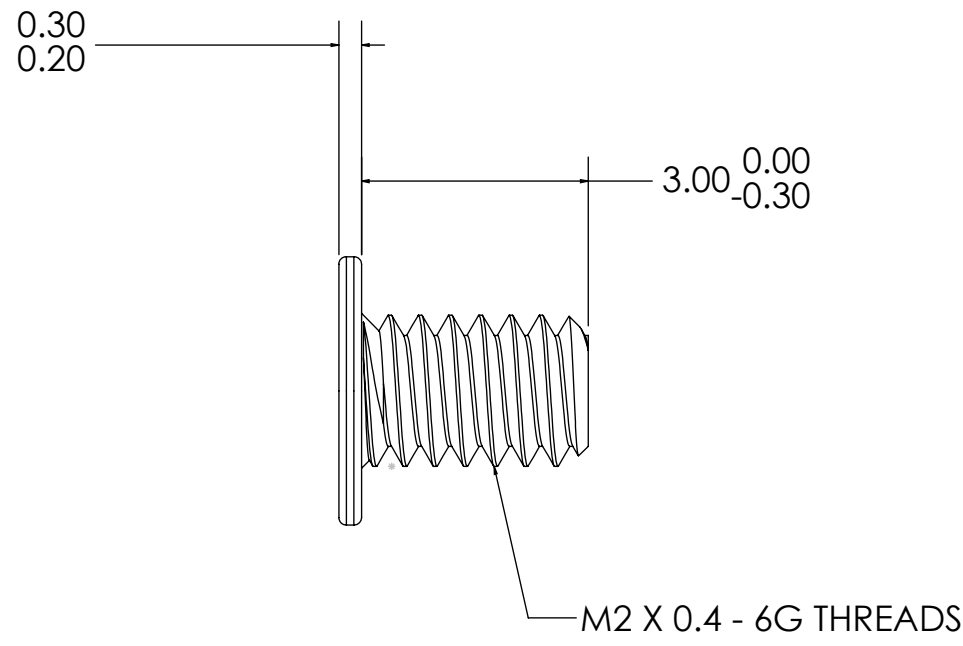
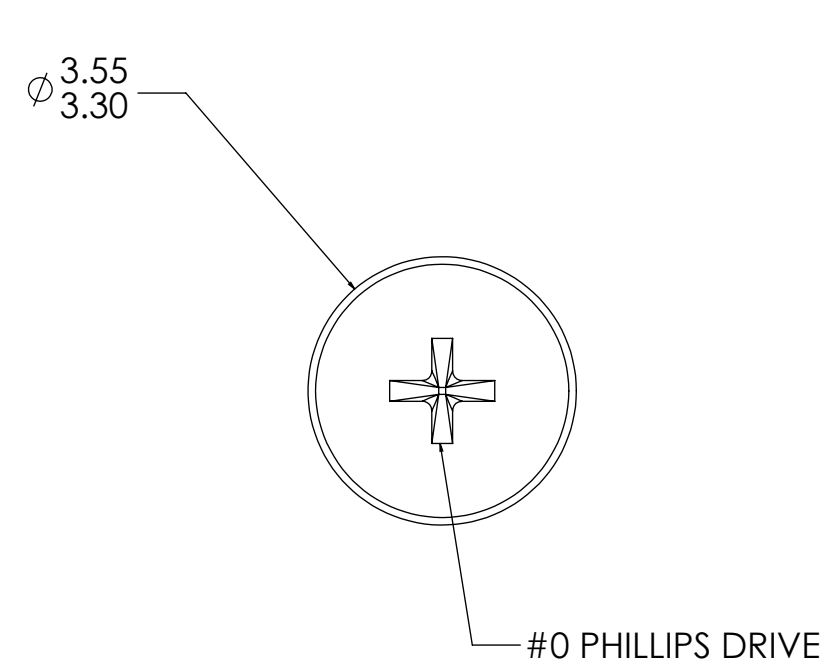
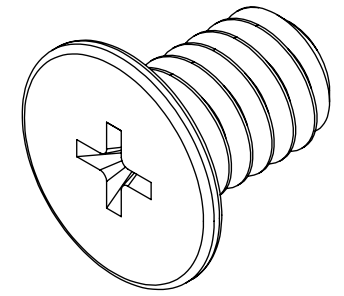

DIMENSIONS ARE IN MM (INCHES) TOLERANCES: <table border="0"> <tr> <td>LINEAR</td> <td>ANGLE</td> </tr> <tr> <td>X.X ±0.5</td> <td>X° ±1°</td> </tr> <tr> <td>X.XX ±0.1</td> <td>X.X° ±0.5°</td> </tr> </table>		LINEAR	ANGLE	X.X ±0.5	X° ±1°	X.XX ±0.1	X.X° ±0.5°	 www.usmicroscrew.com	
LINEAR	ANGLE								
X.X ±0.5	X° ±1°								
X.XX ±0.1	X.X° ±0.5°								
MATERIAL 302 STAINLESS STEEL		TITLE: M2 ULTRA THIN HEAD							
FINISH PASSIVATE TO ASTM A380		SIZE B	DWG. NO. M20-30-M-SS-UT						
		SCALE: 10:1	REV 01						
		WEIGHT:	SHEET 1 OF 1						