

REVISIONS		
REV.	DESCRIPTION	DATE
01	INITIAL RELEASE	2011 11 10

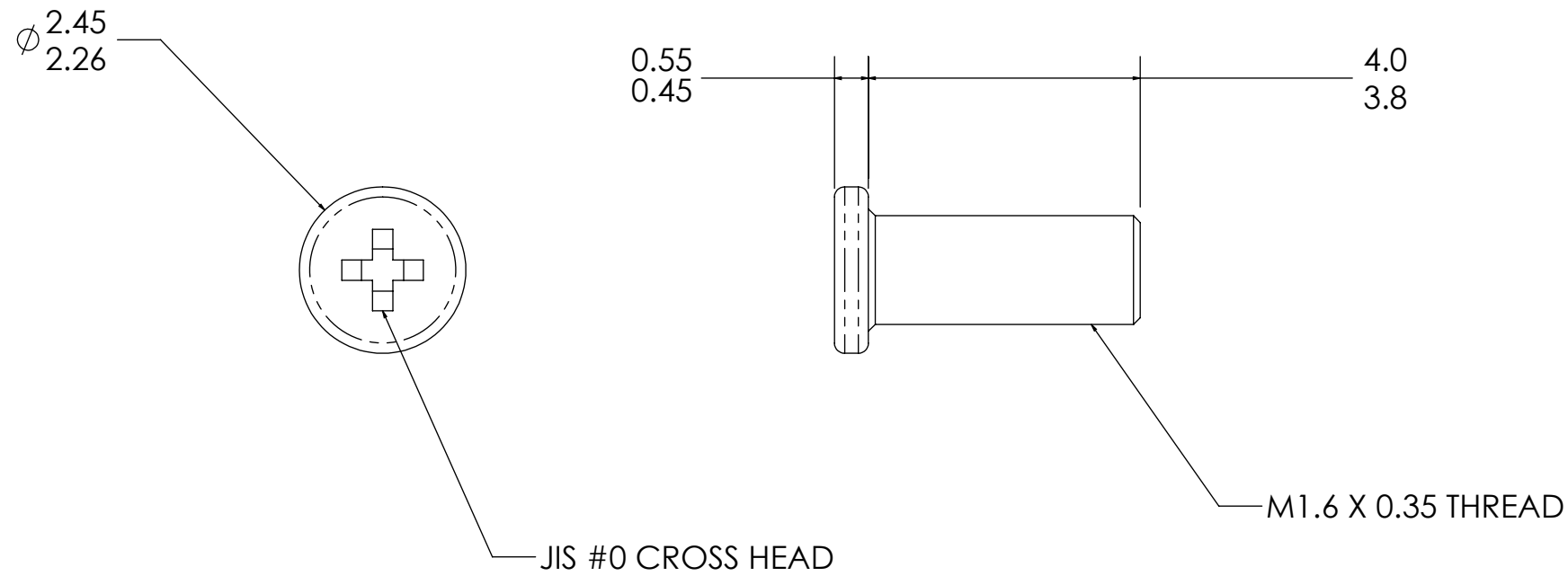
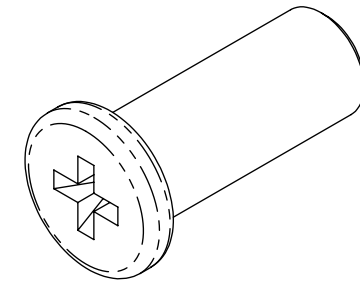

DIMENSIONS ARE IN MM
TOLERANCES:

LINEAR		ANGLE	
X.X	±0.5	X°	±1°
X.XX	±0.1	X.X°	±0.5°

USMICROSCREW
www.usmicroscrew.com

TITLE:
M1.6 x 4mm Pan Head

MATERIAL
302 STAINLESS STEEL

FINISH
NONE

SIZE **B** DWG. NO. M16-40-M-SS-P

REV **01**

SCALE: 10:1 WEIGHT: SHEET 1 OF 1