

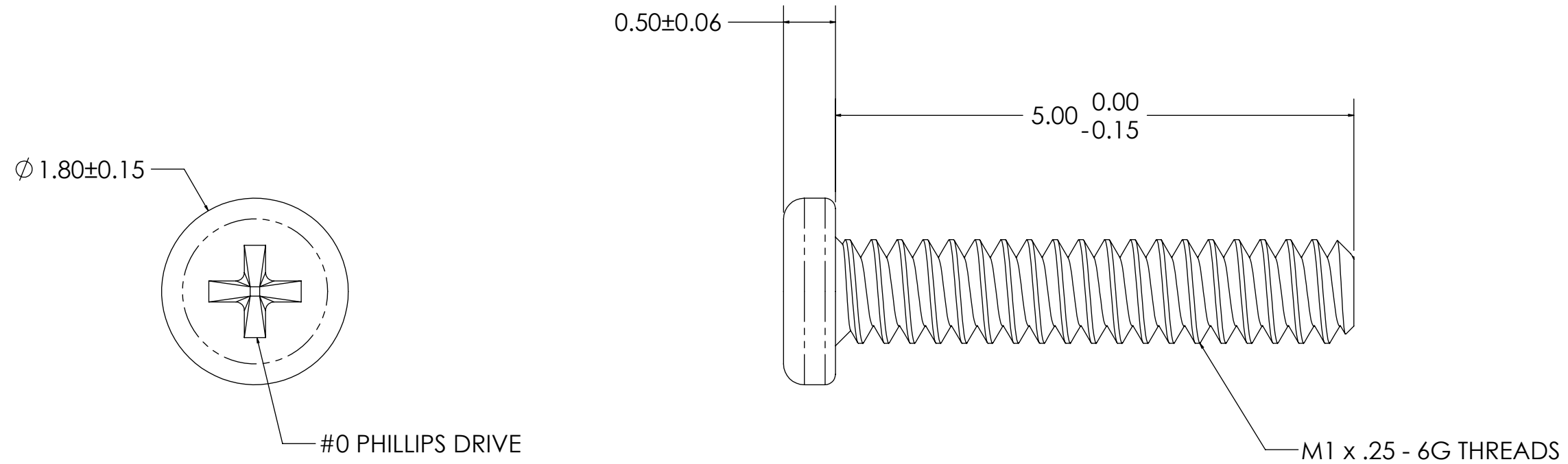

REVISIONS		
REV.	DESCRIPTION	DATE
01	INITIAL RELEASE	2010 11 28

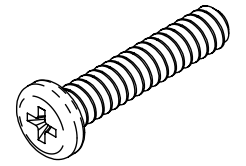

DIMENSIONS ARE IN MM TOLERANCES:		 <a href="http://www.usmicroscrew.com">www.usmicroscrew.com</a>		
LINEAR      ANGLE X.X      ±0.5      X°      ±1° X.XX     ±0.1      X.X°    ±0.5°				
MATERIAL 302 STAINLESS STEEL		SIZE <b>B</b>	DWG. NO. M10-50-M-SS-P	REV <b>01</b>
FINISH PASSIVATED TO ASTM A380		SCALE: 20:1		WEIGHT:
		SHEET 1 OF 1		

