

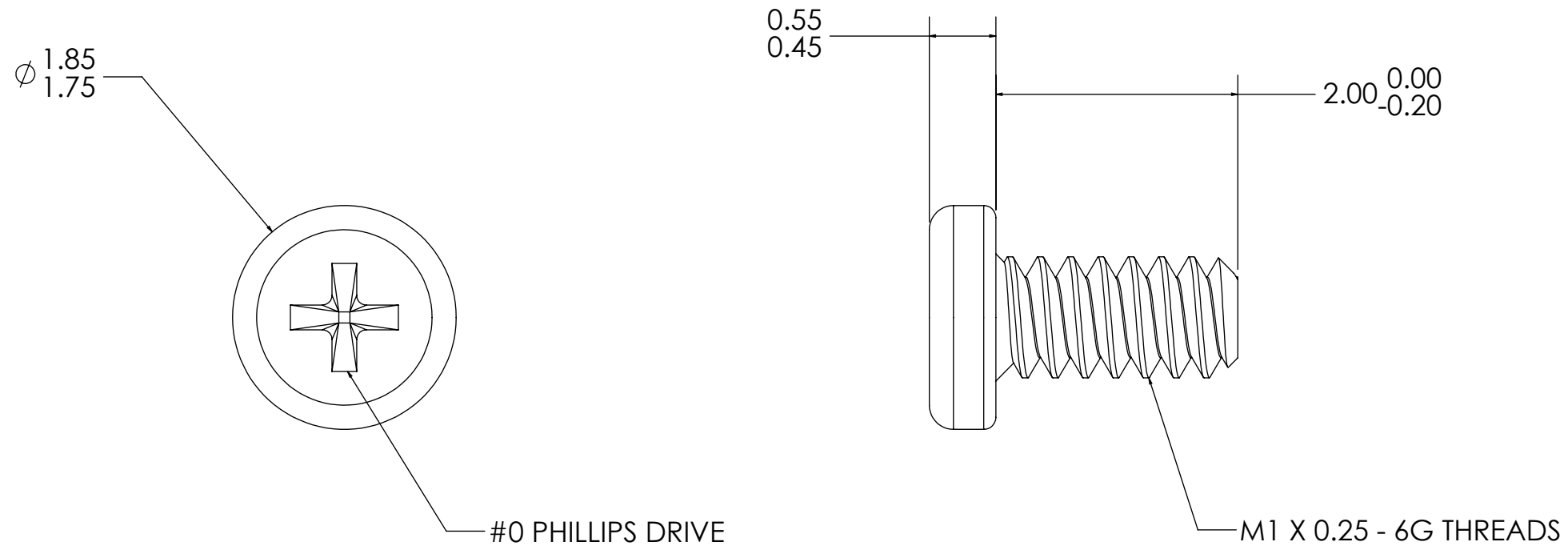

REVISIONS		
REV.	DESCRIPTION	DATE
01	INITIAL RELEASE	2014 05 01

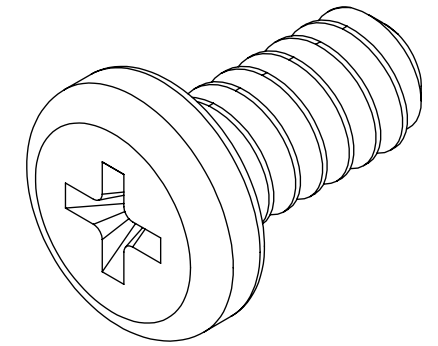

DIMENSIONS ARE IN MM (INCHES) TOLERANCES:		 <a href="http://www.usmicroscrew.com">www.usmicroscrew.com</a>		
LINEAR      ANGLE X.X    ±0.5    X°    ±1° X.XX   ±0.1   X.X°   ±0.5°				
MATERIAL 302 STAINLESS STEEL		SIZE <b>B</b>	DWG. NO. M10-20-M-SS-P	REV <b>01</b>
FINISH PASSIVATED TO ASTM A380		SCALE: 20:1		WEIGHT:      SHEET 1 OF 1