

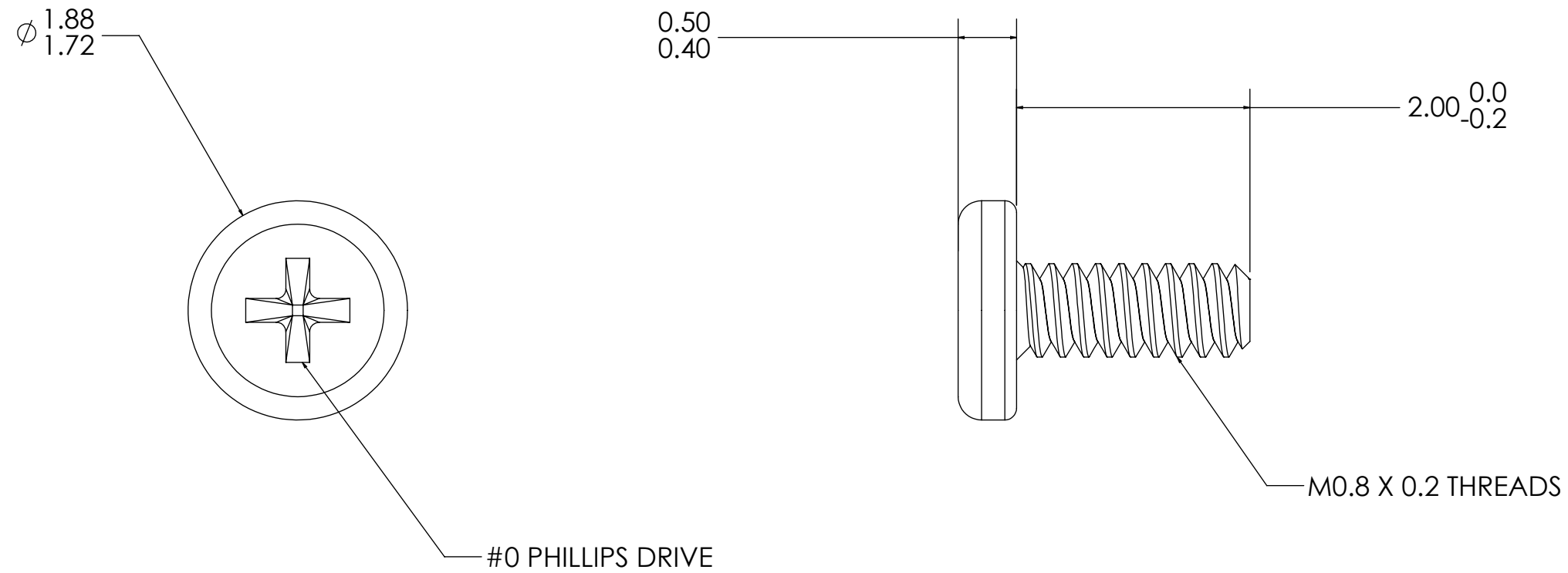

REVISIONS		
REV.	DESCRIPTION	DATE
01	INITIAL RELEASE	2014 04 21

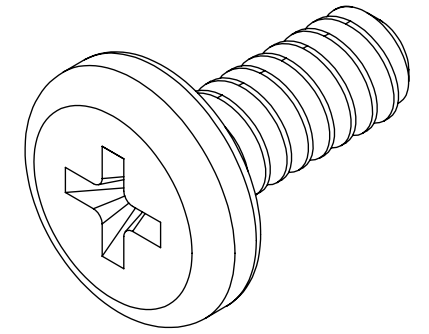

DIMENSIONS ARE IN MM (INCHES) TOLERANCES:		 www.usmicroscrew.com		
LINEAR ANGLE X.X ±0.5 X° ±1° X.XX ±0.1 X.X° ±0.5°				
MATERIAL 302 STAINLESS STEEL		SIZE B	DWG. NO. M08-20-M-SS-P	REV 01
FINISH PASSIVATE TO ASTM A380		SCALE: 20:1		WEIGHT: SHEET 1 OF 1